

Seamless Integration with PowerMill

The PowerMill-to-VERICUT Interface integrates the two programs to help you create the most accurate and efficient NC programs possible!

Using CGTech's interface, you can launch VERICUT from within PowerMill. The interface automatically transfers all stock, fixture, and design models to VERICUT in the correct location. NC programs, cutting tools, machine and control data and other simulation parameters are also transferred seamlessly.

VERICUT verifies NC milling, drilling, turning, EDM, mill/turn, and roll-die machining operations to detect errors without doing a manual proveout. It also optimizes NC programs in order to produce more efficient tool paths that save time, produce higher quality surface finishes, and prolong tool life.

VERICUT simulates multi-operation machining from NC machine code, or PowerMill files. The PowerMill and VERICUT processes run independently so you can continue to work in PowerMill while simulating your NC programs.

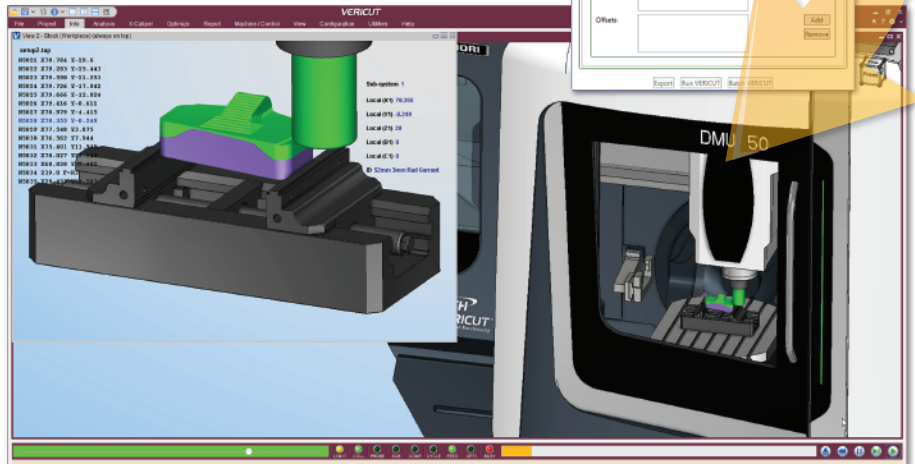
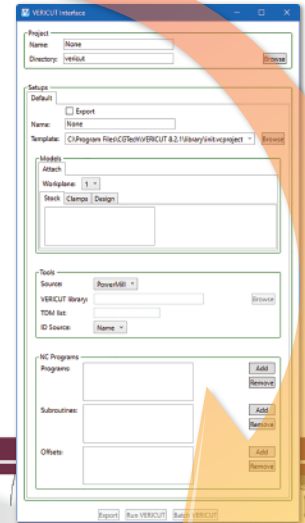
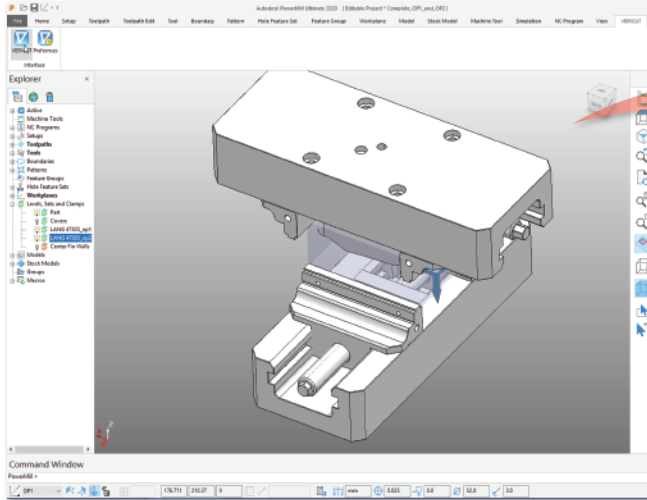

Why PowerMill + VERICUT?

Provides access for PowerMill manufacturing data in VERICUT

Automates setups on VERICUT digital twin machines

Verifies same G-code programs that run on CNC machines

Right the first time. Every time.

9000 Research Dr, Irvine, California 92618
(949) 753-1050 • info@cgtech.com

CGTECH.com

Go ahead...

CRASH YOUR MACHINE

...as long as it's in VERICUT

NC Program Verification, Inspection & Analysis, CAD Export

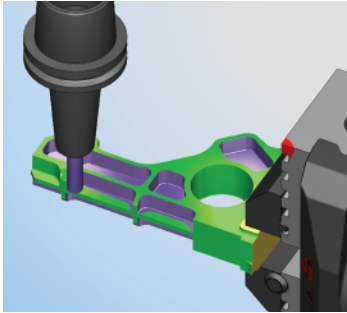

VERICUT simulates milling, drilling, turning, multi-tasking mill/turn, and EDM operations. Errors that could ruin the part, damage the fixture, or break the cutting tool are easily identified. VERICUT supports G-codes and native CAM files and includes analysis tools to measure and compare the cut part with the design model. You can model any cutter, fixture, or holder shape. During simulation you create in-process inspection instructions and export a CAD model of the "as-machined" part.

- Eliminate program errors
- Reduce scrap and rework
- Train without using a machine
- Improve documentation and presentations
- Consistently produce perfect first-time programs without manual prove-outs

CNC Machine Simulation

A single crash can be extremely expensive, ruin the machine, and delay the entire production schedule! VERICUT enables you to simulate your CNC machines so you can detect collisions between portions of the machine, the part, fixtures and holders, etc. before any actual cutting occurs. And, because the simulation is driven by the same logic as the machine's control, it behaves exactly like the physical machine and is the most accurate collision-checking available.

- Eliminate crashes & close calls
- Check machine capabilities
- Improve process efficiency
- Speed up machine implementation time
- Enhance documentation
- Increase safety and improve training

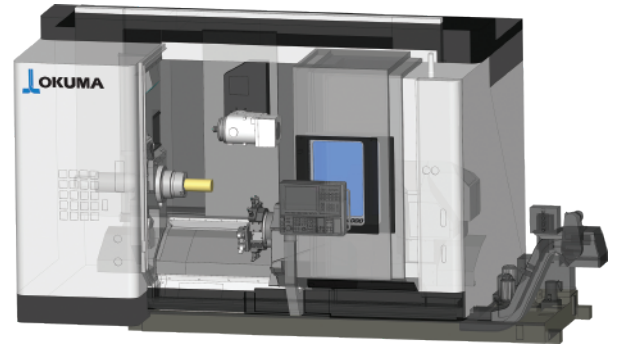

Feed Rate Optimization

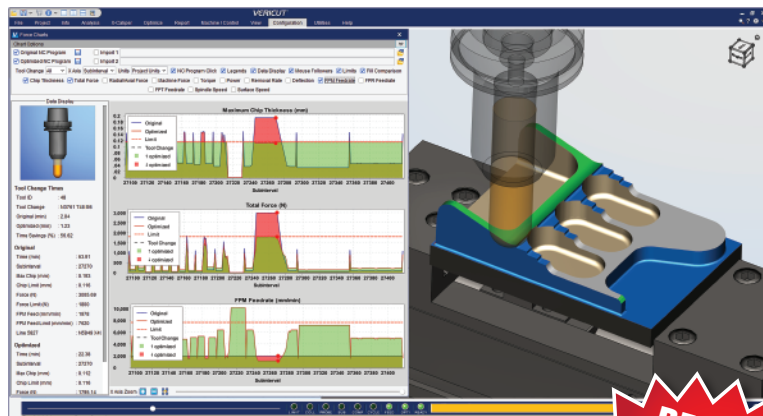

VERICUT is equipped with NC program optimization capabilities. Based on the cutting tool geometry, part material, and programmed cutting conditions, VERICUT automatically determines the optimum safe feed rate for each cut. The VERICUT optimized NC program will greatly improve cutter performance resulting in significant cycle time savings, reduced tool wear, improved tool life, and better finished parts.

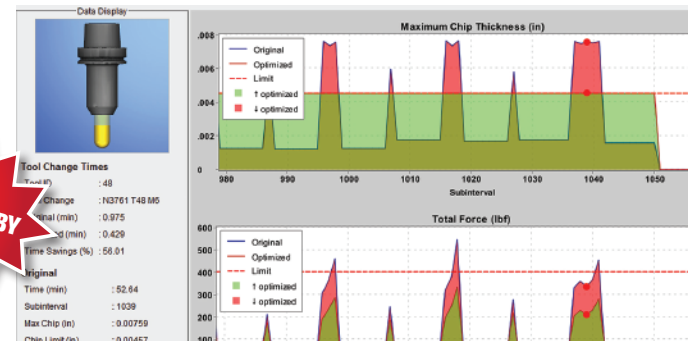

REDUCES MACHINING TIME BY 15-25%

- Improve cutting tool performance
- Prevention of undesirable cutting conditions
- Eliminate manual feed adjustments at the machine
- Utilize cutting tool technologies to their full potential
- Maximized and consistent chip thickness throughout the machining process

© CGTech 2020. All rights reserved. CGTech and VERICUT are registered trademarks of CGTech.

Right the first time. Every time.

9000 Research Dr, Irvine, California 92618
(949) 753-1050 • info@cgtech.com

